

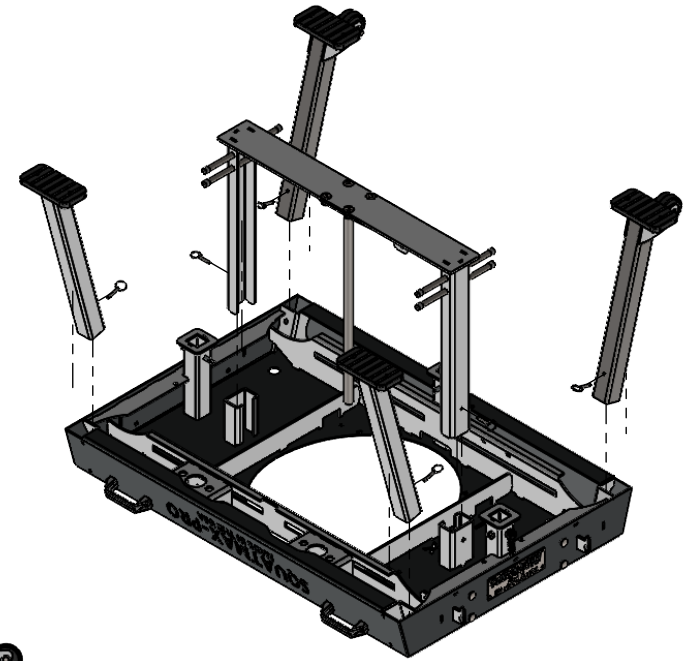

STEP 1:

- POSITION BASE WITH TOP FACE DOWN AND ONE END PROPPED UP ENOUGH FOR THE LOAD PIN TO PROTRUDE THROUGH AFTER ASSEMBLY (APPROX 6 INCHES).
- USE CARE WHEN REMOVING BASE FROM CRATE NOT TO DRAG TOP SURFACE ACROSS METAL BRACKETS CAUSING DAMAGE TO FINISH.
- INSERT LEGS AND FOOT PLATE. WHEELED LEGS ARE LOACTED OPOSIDE THE BASE HANDLES.
- INSERT 6X 1" QUICK RELEASE PINS AS SHOWN TO SECURE LEGS AND FOOTPLATE.
- REMOVE RUBBER SHIPPING CAPS FROM BAND PEGS ON FOOT PLATE AND LOAD PIN.

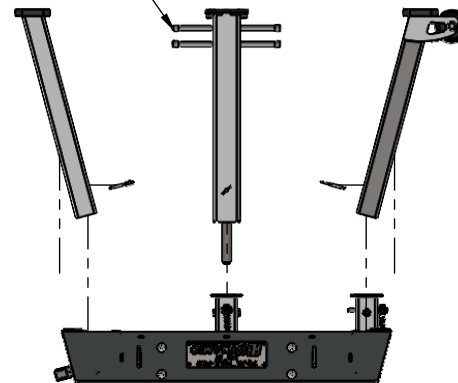
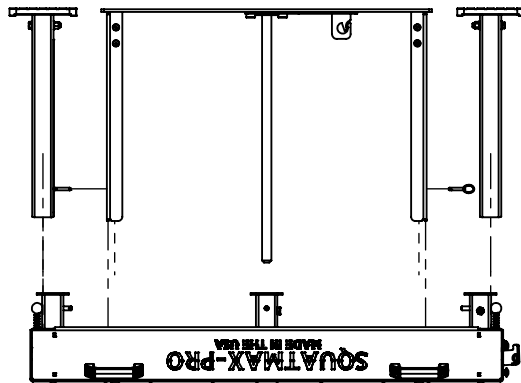

REMOVE AND DISCARD CAPS



	NAME	DATE		
DRAWN	KW	2/27/2025		
CHECKED			TITLE:	
COMMENTS:			SQUATMAX PRO	
			ASSEMBLY STEP 1	
SIZE	DWG. NO.	REV		
A	713038	-		
SCALE: 1:18		WEIGHT: 165.941	SHEET 1 OF 3	

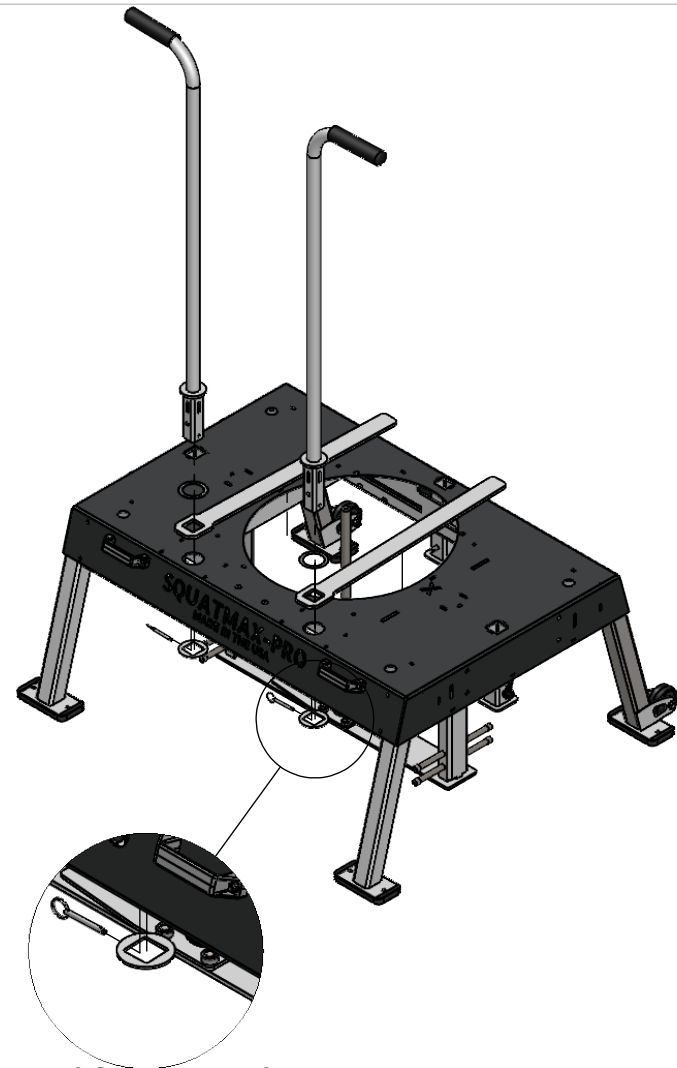
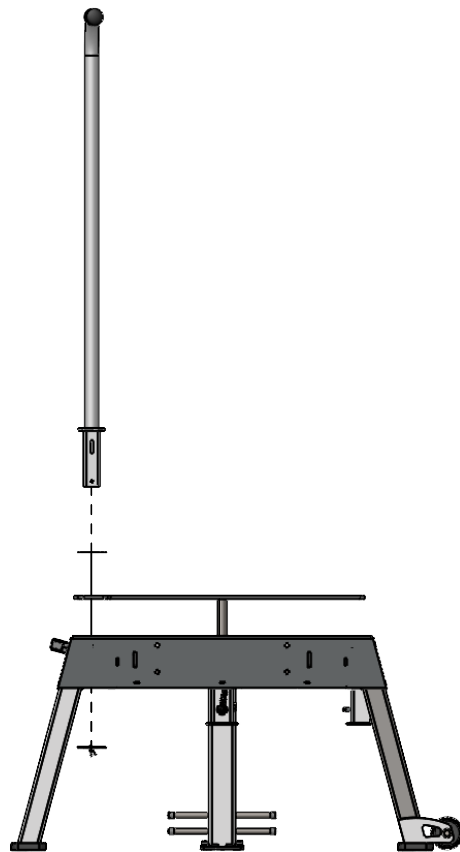
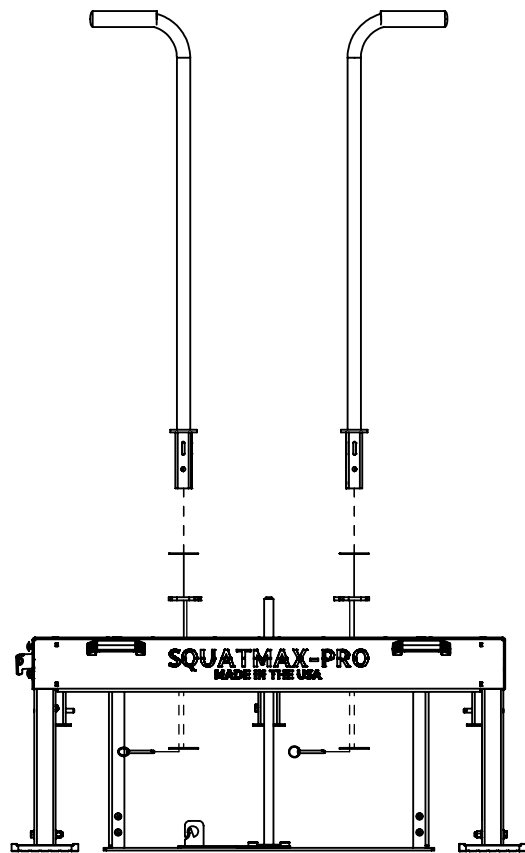

STEP 2:

- FLIP UNIT OVER SO IT IS RESTING ON THE 4 FEET
- INSERT LOAD BARS INTO BASE. END WITH CUTOUT MUST BE INSERTED INTO HANDLE HOUSING FIRST. PLAIN END IS ROTATED INTO SLOT ON OPPOSITE SIDE
- PLACE 2X PLASTIC WASHERS OVER HANDLE HOLES ON BASE TOP. INSERT HANDLES THROUGH HOLES. ROTATE HANDLES TO PASS THEM THROUGH LOAD BAR CUTOUTS.
- SECURE HANDLES ON UNDERSIDE OF BASE WITH SQUARE CUTOUT WASHERS AND 2" QUICK RELEASE PINS

DETAIL A: SQUARE WASHER AND PIN
SCALE 1:9

	NAME	DATE			
DRAWN	KW	2/27/2025			
CHECKED			TITLE: SQUATMAX PRO ASSEMBLY STEP 2		
COMMENTS:			SIZE A	DWG. NO. 713038	REV -
			SCALE: 1:18 WEIGHT: 190.565 SHEET 2 OF 3		

STEP 3:

- ATTACH J-CUPS TO BASE. BAR RETAINERS AND BOLTS ARE PREINSTALLED, BUT J-CUPS ARE REMOVED FOR SHIPPING. REMOVE 4X CARRIAGE BOLTS AND NYLOC NUTS FROM INSIDE OF BASE AND INSTALL J-CUPS. 9/16" WRENCH/SOCKET IS REQUIRED TO TIGHTEN NUTS.
- CHECK THAT BAR RETAINERS SLIDE FREELY AFTER ATTACHING J-CUPS. IF THERE IS BINDING IT MAY BE NECESSARY TO LOOSEN BOLTS AND REPOSITION SO BARS ARE CENTERED IN SLOT.

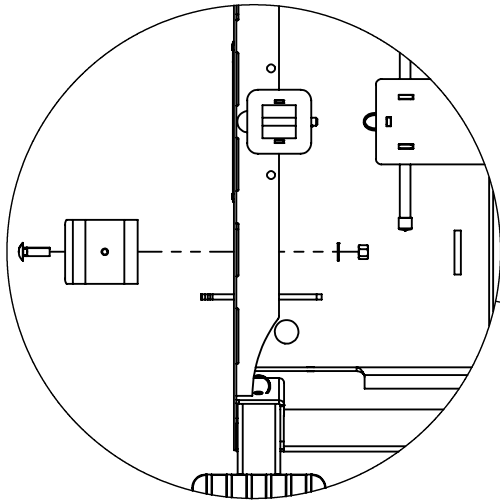

DETAIL B
SCALE 1:9

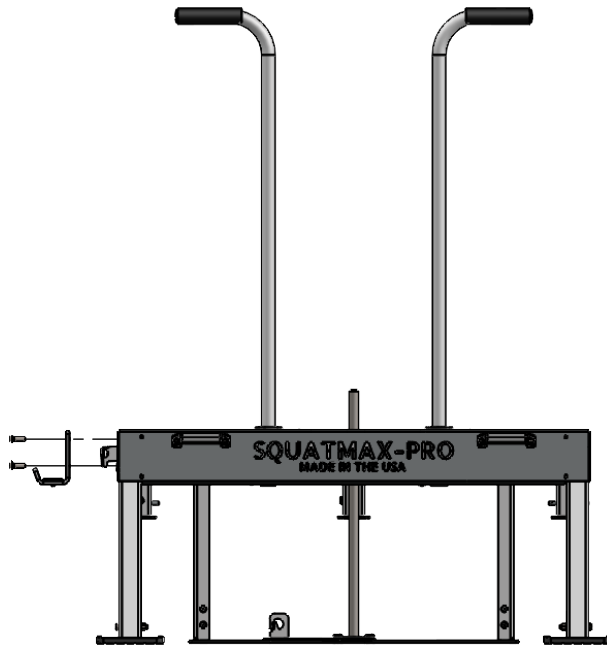
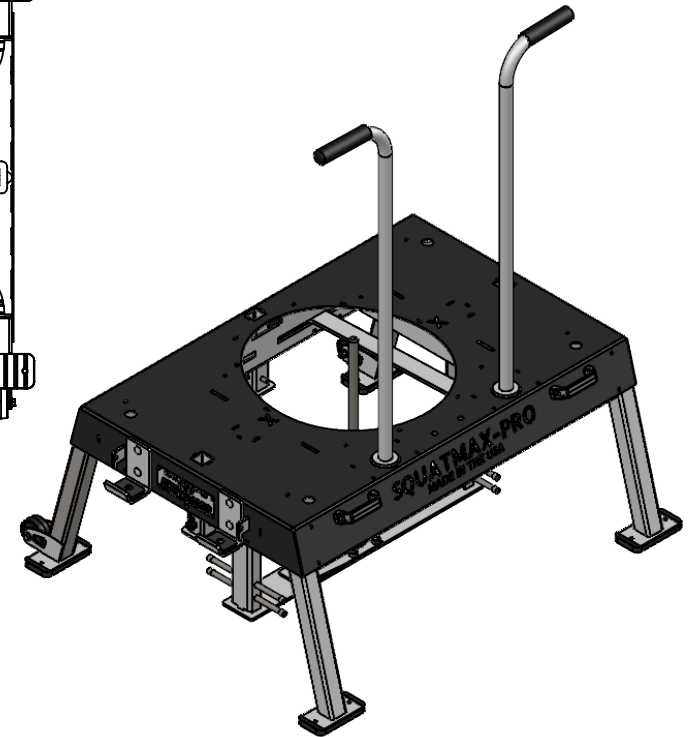
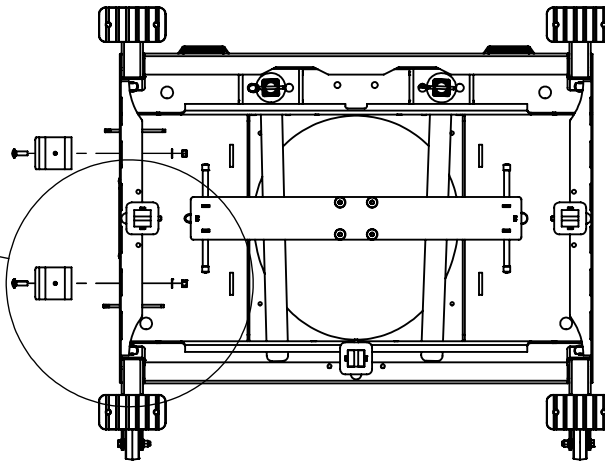

	NAME	DATE			
DRAWN	KW	2/27/2025			
CHECKED			TITLE:		
COMMENTS:			SQUATMAX PRO ASSEMBLY STEP 3		
			SIZE	DWG. NO.	REV
			A	713038	-
			SCALE: 1:18	WEIGHT: 195.1413	SHEET 3 OF 3